

**GROUP 27**

**BG27**



**SNAP-TOP BATTERY BOX.**

**ULTIMATE PROTECTION.**

**IMPACT RESISTANT**  
DOWN TO -20°F.

**RESISTANT TO**  
ACID, GAS, OIL, UV.



**NOCO**

30339 Diamond Parkway, #102  
Glenwillow, OH 44139 | USA  
1.800.456.6626

no.co

# ALL NEW DESIGN.

**REINFORCED  
STRUCTURE.**

**IMPROVED  
LOCKING TABS.**

**HEAVY-DUTY  
HANDLES.**

**EASY INSTALLATION.  
MULTIPLE OPTIONS FOR INSTALLATION.**

# MAXIMUM VERSATILITY.

**MULTIPLE CABLE PORTS.**

Multiple cable ports offer easy installation for a variety of applications.



## OPTION 1: DIRECT MOUNT

Use predetermined mounting locations to fasten box directly to mounting surface.

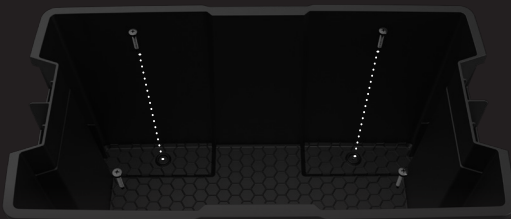

## OPTION 2: STRAP MOUNT

**STEP 1**  
Fasten mounting plate to desired location.

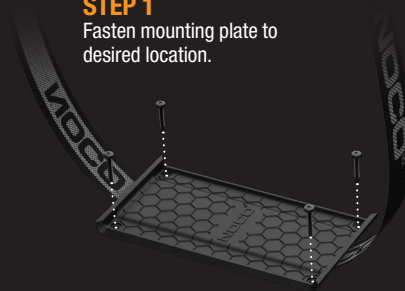

## STEP 2

Use strap to fasten box to mounting tray.



## WHAT'S IN THE BOX

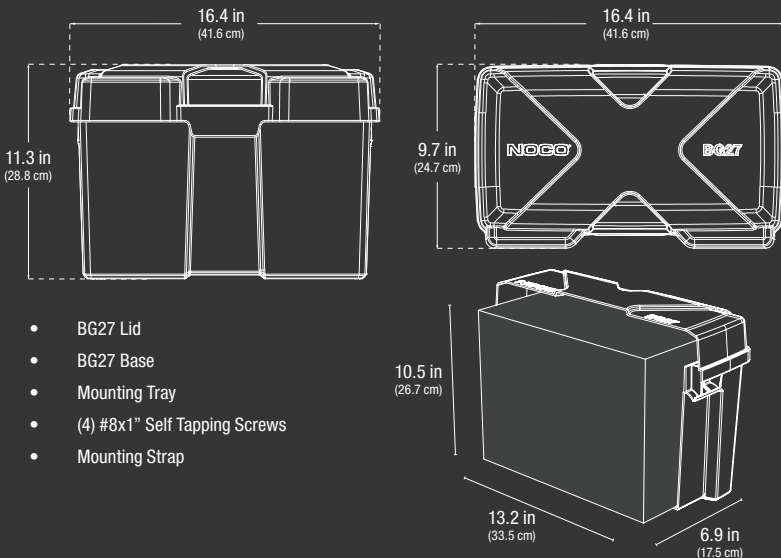

## TECHNICAL SPECIFICATIONS

<b>BATTERY GROUP:</b>	Group 27												
<b>WEIGHT:</b>	3.00 lbs (1.36kg)												
<b>CERTIFICATIONS:</b>	<ul style="list-style-type: none"><li>• Meets Coast Guard (USCG) Code of Federal Regulations 183.420.</li><li>• Meets American Boat and Yacht Council (ABYC) E-10.7.</li></ul>												
<b>VOLUMETRICS:</b>	<table><tbody><tr><td><b>Retail Packaging:</b></td><td><b>Master Carton:</b></td></tr><tr><td>Dimensions: 16.40" x 9.70" x 11.30"</td><td>Dimensions: 16.50" x 9.88" x 34.50"</td></tr><tr><td>Weight: 3.16 lbs</td><td>Weight: 19.85 lbs</td></tr><tr><td>UPC: 00046221220100</td><td>Quantity: 6</td></tr><tr><td></td><td>UCC: 10046221220107</td></tr><tr><td></td><td><b>Units Per Pallet:</b> 150 Units</td></tr></tbody></table>	<b>Retail Packaging:</b>	<b>Master Carton:</b>	Dimensions: 16.40" x 9.70" x 11.30"	Dimensions: 16.50" x 9.88" x 34.50"	Weight: 3.16 lbs	Weight: 19.85 lbs	UPC: 00046221220100	Quantity: 6		UCC: 10046221220107		<b>Units Per Pallet:</b> 150 Units
<b>Retail Packaging:</b>	<b>Master Carton:</b>												
Dimensions: 16.40" x 9.70" x 11.30"	Dimensions: 16.50" x 9.88" x 34.50"												
Weight: 3.16 lbs	Weight: 19.85 lbs												
UPC: 00046221220100	Quantity: 6												
	UCC: 10046221220107												
	<b>Units Per Pallet:</b> 150 Units												

**NOCO**

30339 Diamond Parkway, #102  
Glenwillow, OH 44139 | USA  
1.800.456.6626

no.co