

GROUP 24

BG24



SNAP-TOP BATTERY BOX.

ULTIMATE PROTECTION.

IMPACT RESISTANT
DOWN TO -20°F.

RESISTANT TO
ACID, GAS, OIL, UV.



NOCO

30339 Diamond Parkway, #102
Glenwillow, OH 44139 | USA
1.800.456.6626

no.co

ALL NEW DESIGN.

**REINFORCED
STRUCTURE.**

**IMPROVED
LOCKING TABS.**

**HEAVY-DUTY
HANDLES.**

**EASY INSTALLATION.
MULTIPLE OPTIONS FOR INSTALLATION.**

MAXIMUM VERSATILITY.

MULTIPLE CABLE PORTS.

Multiple cable ports offer easy installation for a variety of applications.



OPTION 1: DIRECT MOUNT

Use predetermined mounting locations to fasten box directly to mounting surface.

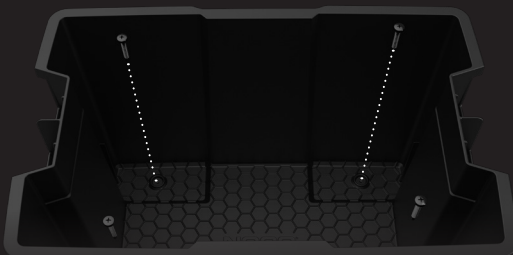

OPTION 2: STRAP MOUNT

STEP 1
Fasten mounting plate to desired location.

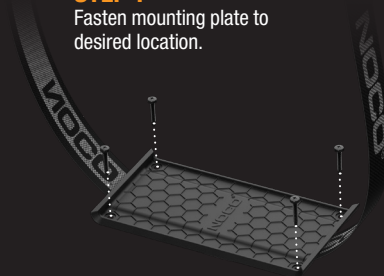

STEP 2

Use strap to fasten box to mounting tray.



WHAT'S IN THE BOX

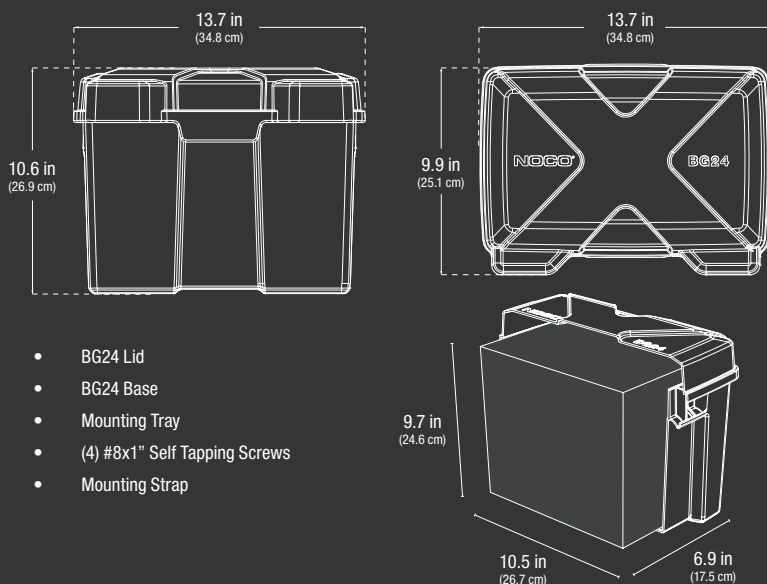

TECHNICAL SPECIFICATIONS

BATTERY GROUP:	Group 24										
WEIGHT:	2.33 lbs (1.06kg)										
CERTIFICATIONS:	<ul style="list-style-type: none">• Meets Coast Guard (USCG) Code of Federal Regulations 183.420.• Meets American Boat and Yacht Council (ABYC) E-10.7.										
VOLUMETRICS:	<table><tr><td>Retail Packaging:</td><td>Master Carton:</td></tr><tr><td>Dimensions: 13.70" x 9.90" x 10.60"</td><td>Dimensions: 13.88" x 10.13" x 33.13"</td></tr><tr><td>Weight: 3.10 lbs</td><td>Weight: 15.55 lbs</td></tr><tr><td>UPC: 00046221220094</td><td>Quantity: 6</td></tr><tr><td></td><td>UCC: 10046221220091</td></tr></table>	Retail Packaging:	Master Carton:	Dimensions: 13.70" x 9.90" x 10.60"	Dimensions: 13.88" x 10.13" x 33.13"	Weight: 3.10 lbs	Weight: 15.55 lbs	UPC: 00046221220094	Quantity: 6		UCC: 10046221220091
Retail Packaging:	Master Carton:										
Dimensions: 13.70" x 9.90" x 10.60"	Dimensions: 13.88" x 10.13" x 33.13"										
Weight: 3.10 lbs	Weight: 15.55 lbs										
UPC: 00046221220094	Quantity: 6										
	UCC: 10046221220091										
	Units Per Pallet: 150 Units										

NOCO

30339 Diamond Parkway, #102
Glenwillow, OH 44139 | USA
1.800.456.6626

no.co